

MODEL ENGINE INSTRUCTIONS

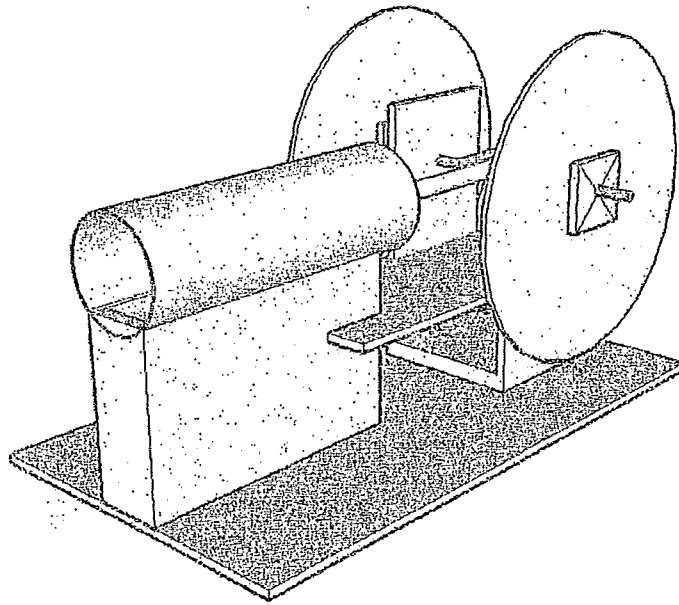

Model Engine Parts List

Engine base	5" x 8 ¾"
Cylinder support	9" x 2 ½"
Crankshaft support	2" x 10 ¼"
Crank Bearings	1 ¼" x 1 ¼" (need 2)
Spacer plate	5" x 2 ¼"
Crankshaft	7" wire
Flywheel Spacers	1' x 1" plastic board (need 4)
Flywheel	CD (need 2)
Piston	Ping pong ball
Connecting Rod	¼" dowel 4 ¼" long
Cylinder	Toilet paper tube 4 ½" long

Directions:

- 1) Cut out the pieces of cardboard listed above.
- 2) Measure and bend the cardboard as shown in the illustrations for the cylinder support and crankshaft support.
- 3) Assemble and glue the pieces together as shown.

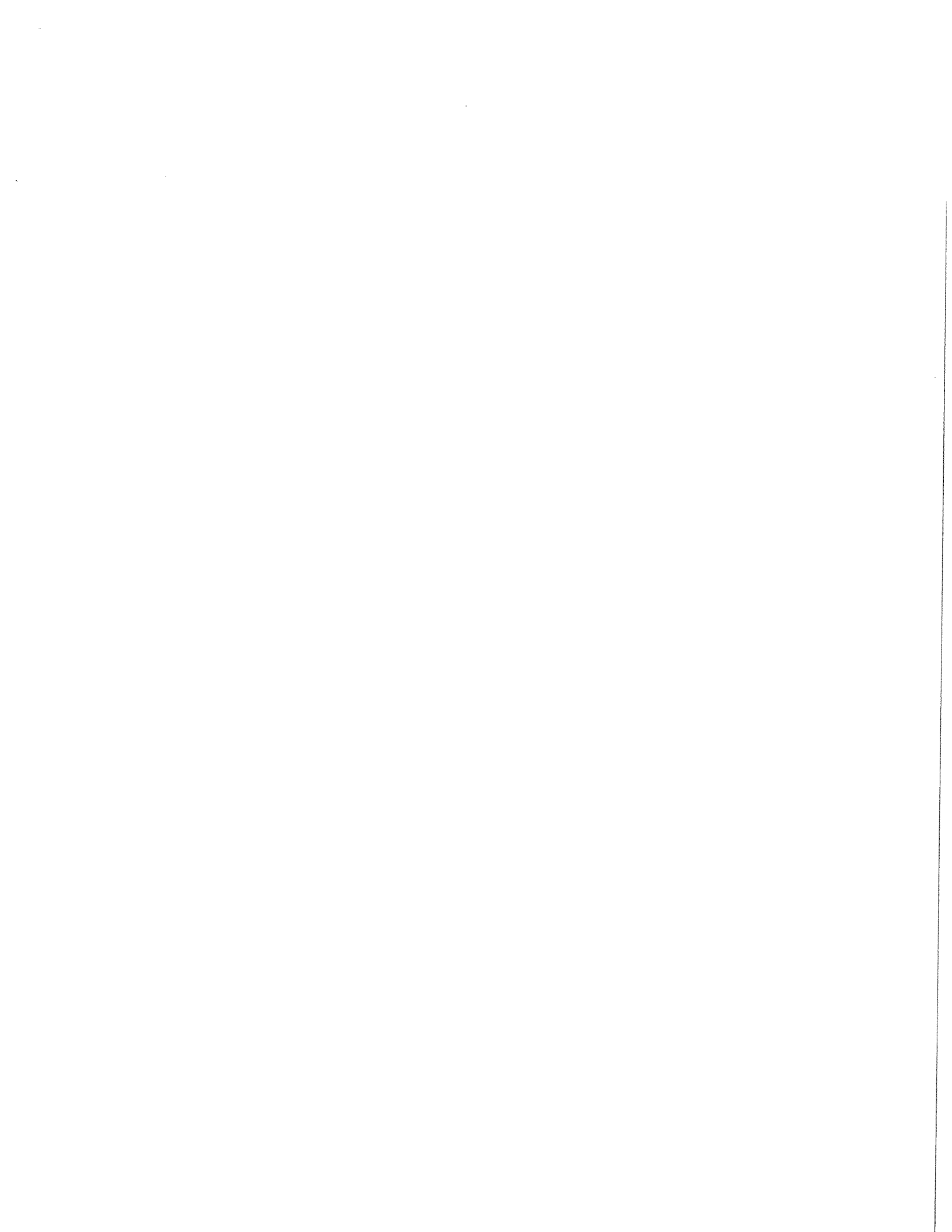

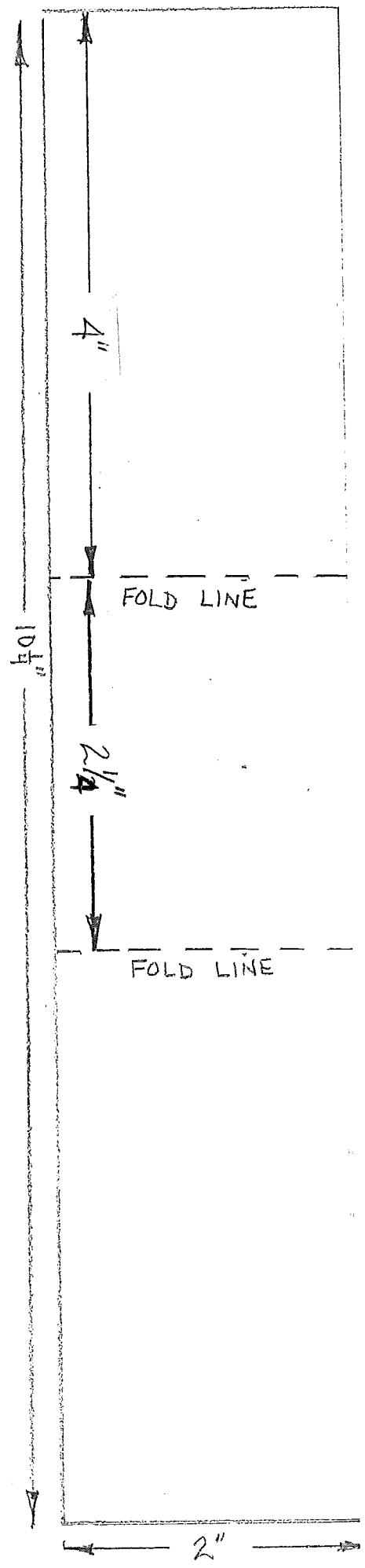
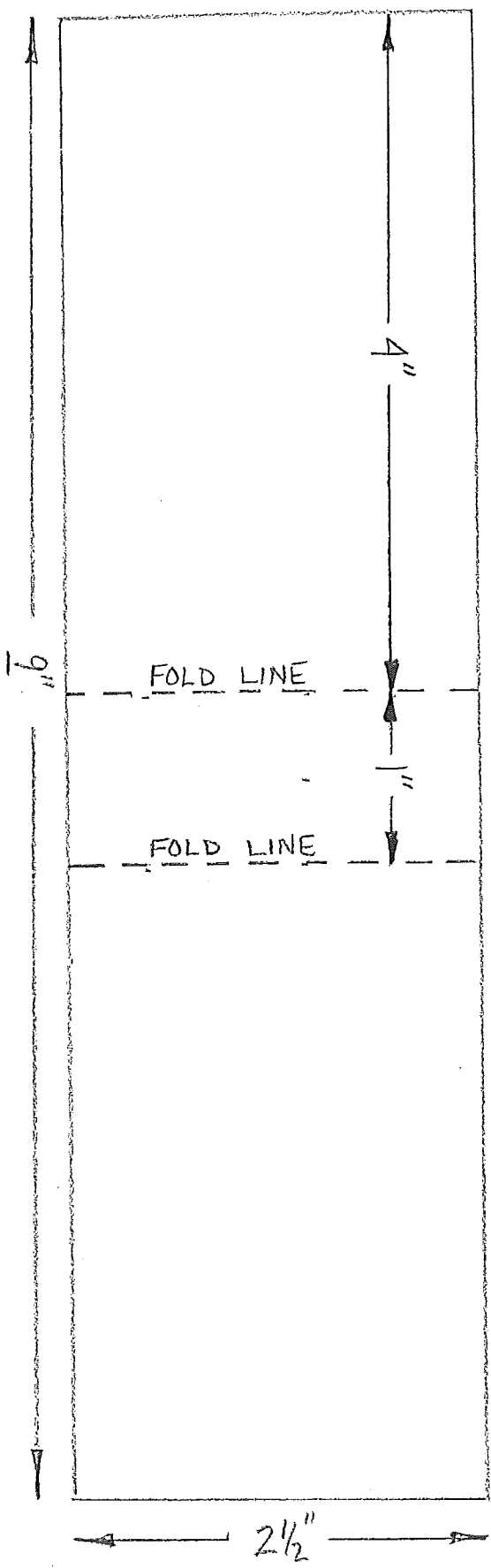
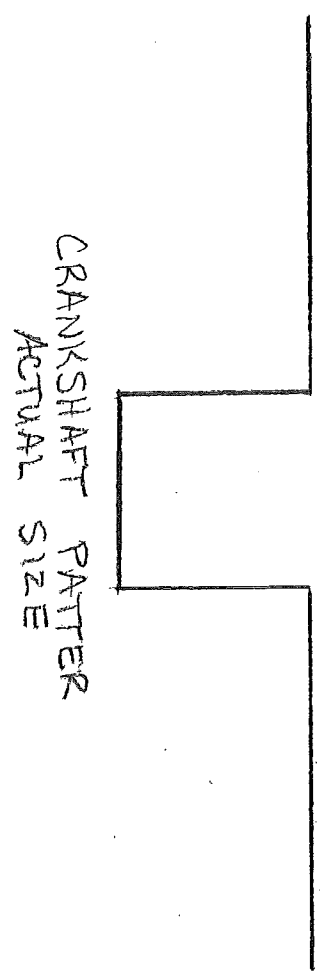
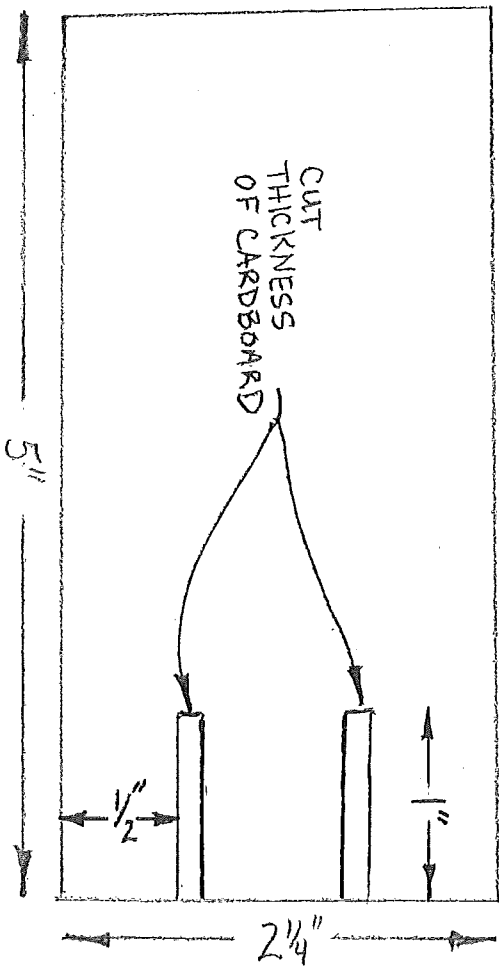

CYLINDER SUPPORT LOCATION

(Do not cut)

CRANK SUPPORT

LOCATION

(Do not cut)

ENGINE BASE

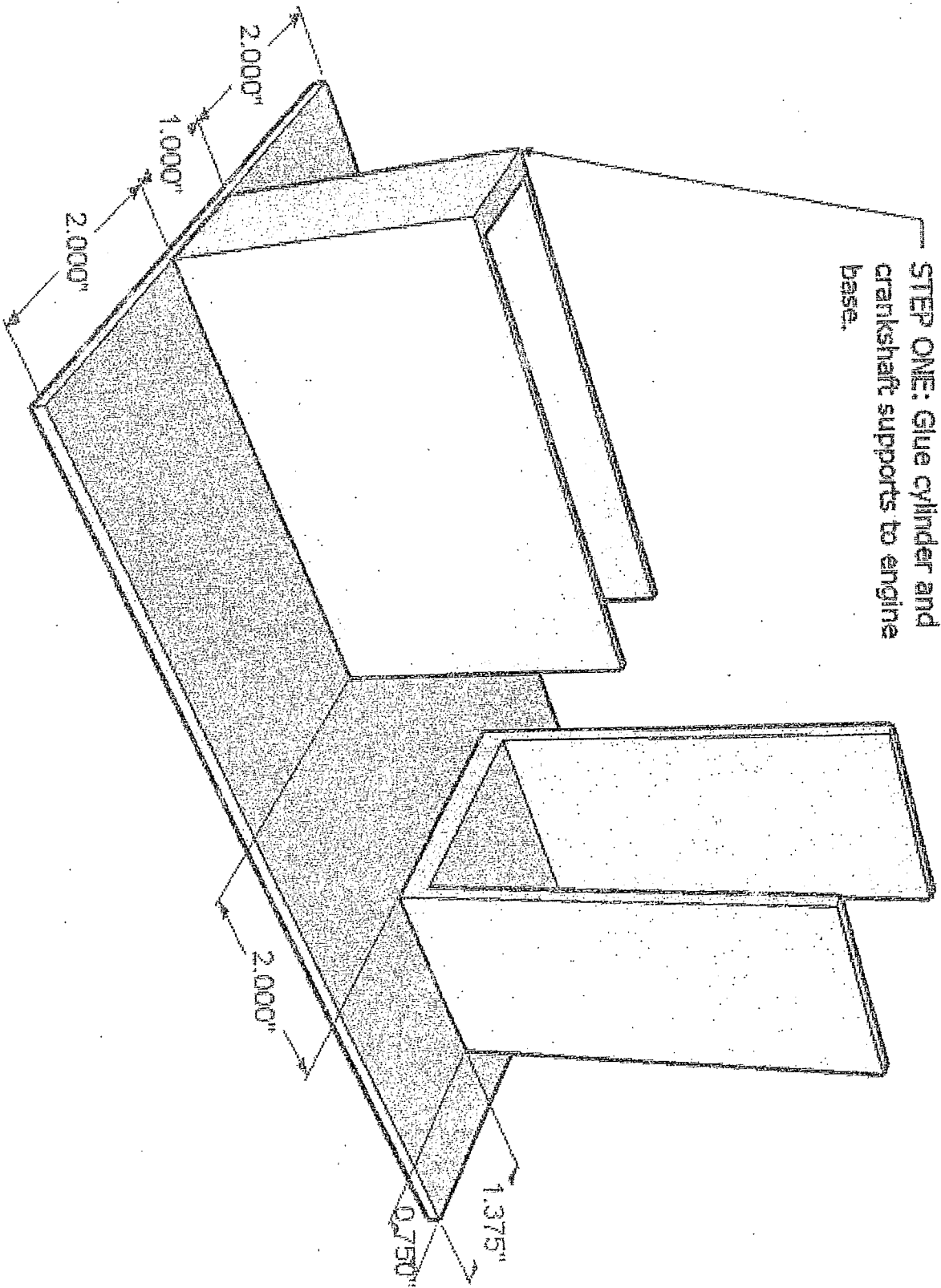

STEP ONE: Glue cylinder and crankshaft supports to engine base.

STEP TWO: Install Spacer
Plate and Crank Bearings
on BOTH SIDES of Crank
Support.

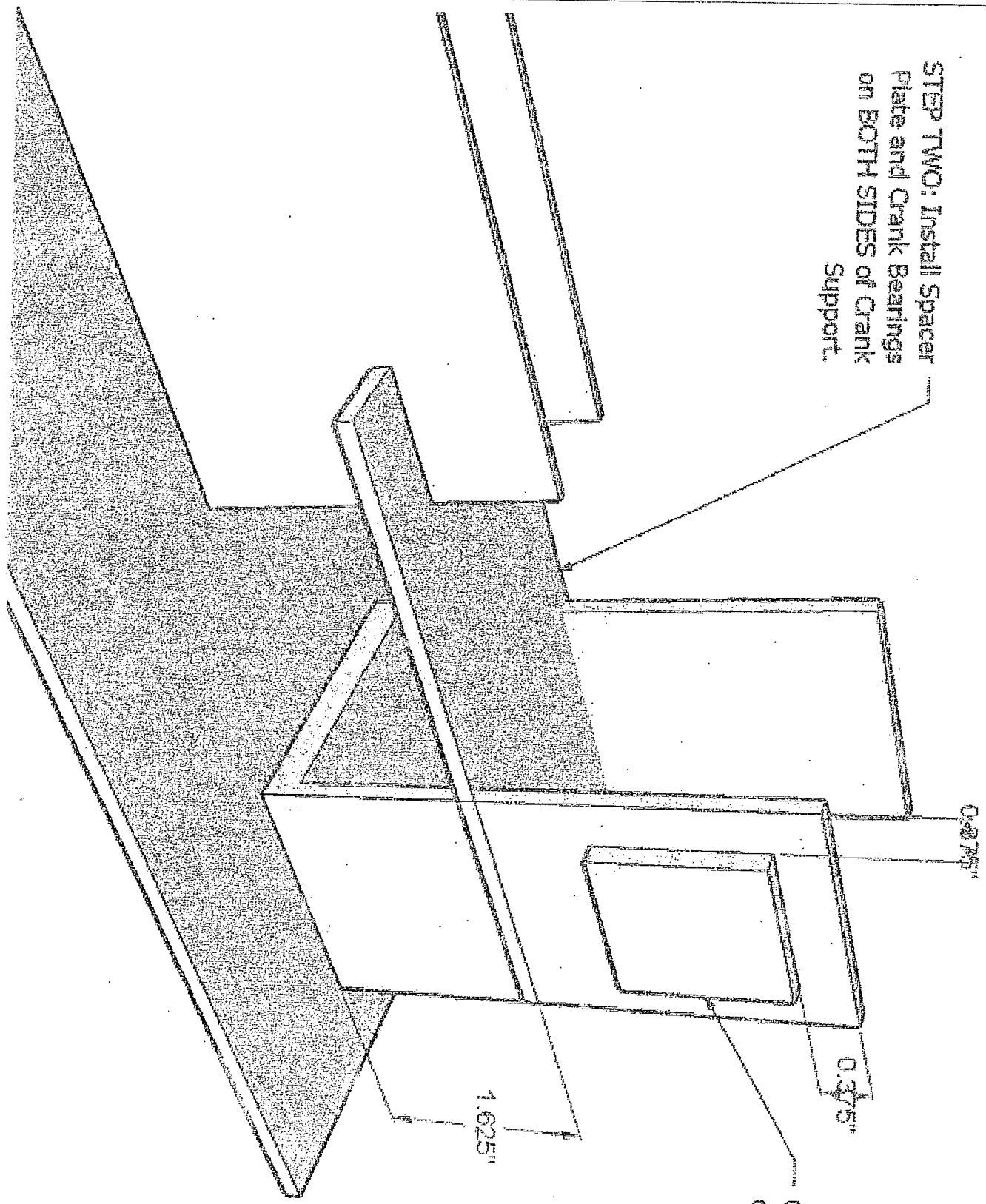

Crank Bearing (0.375"
on other side too.)

STEP THREE: Build the crankshaft
by bending a 7" long piece of wire
as shown. *****NOTE***** You must
put the connecting rod in before you
finish!!!

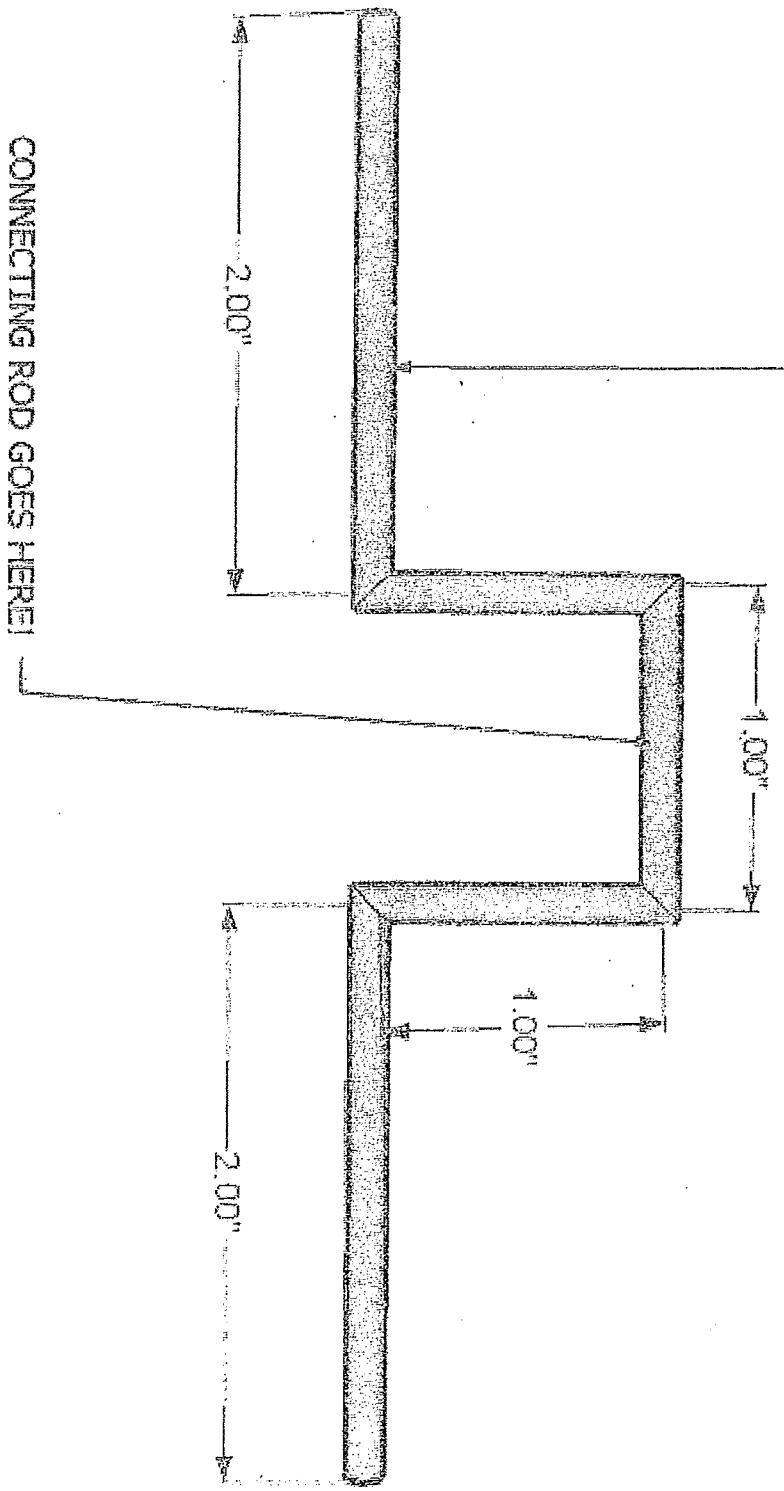

STEP FOUR: Glue the piston onto the connecting rod.

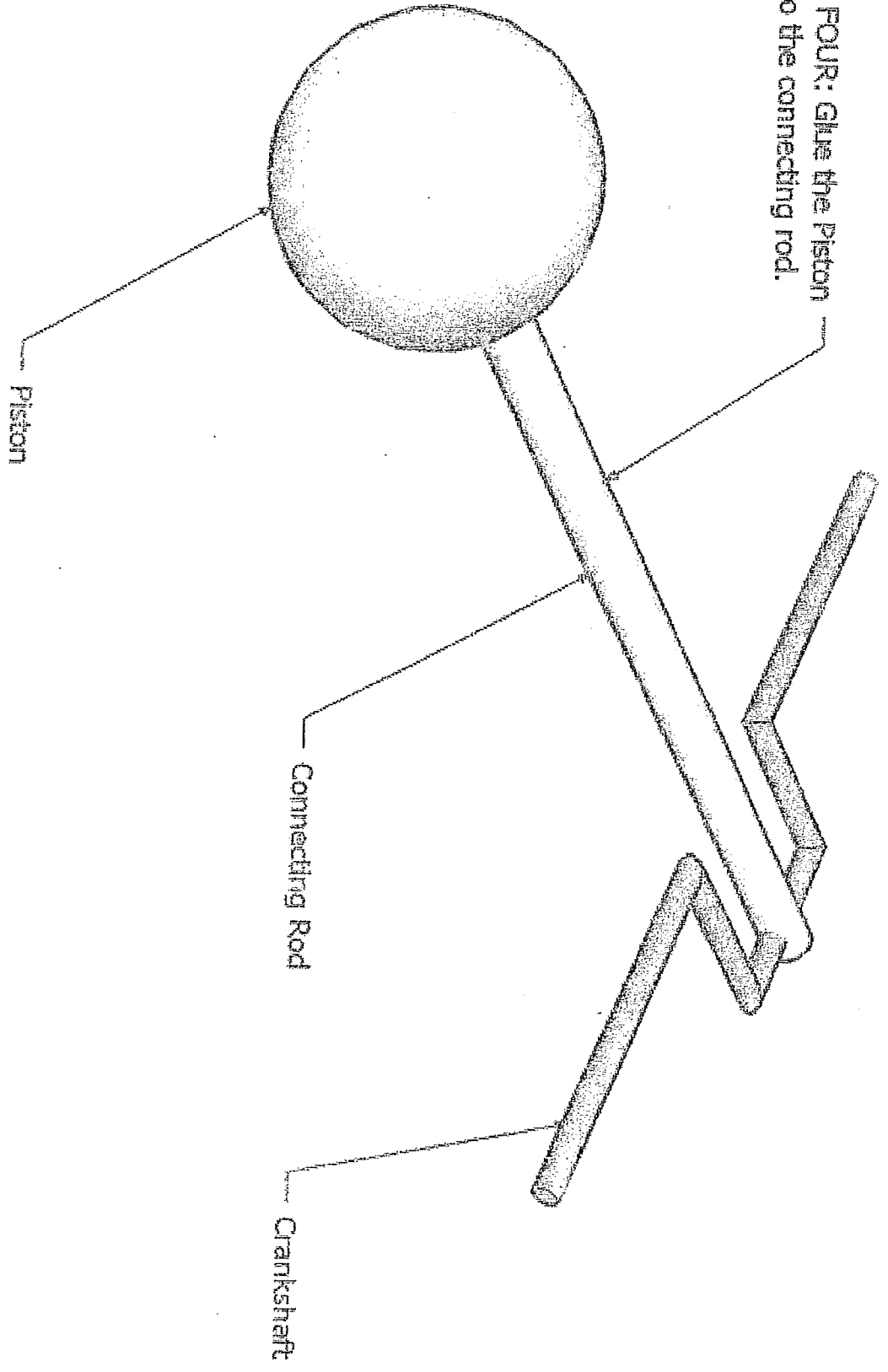

STEP FIVE: Find the center of the Crank Bearings by drawing two lines from corner to corner as shown. Poke holes in both sides, and insert the crankshaft.

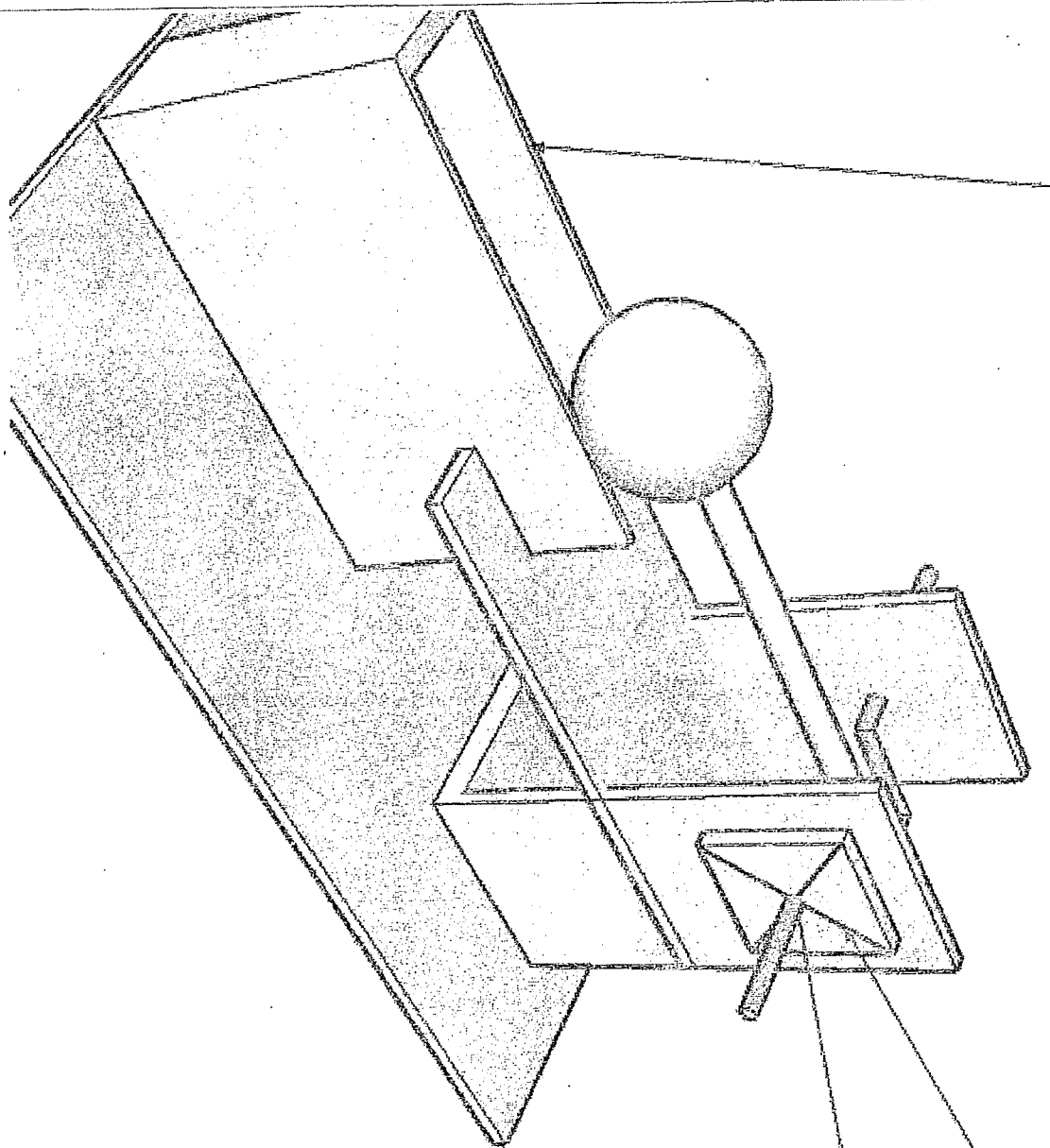

Locating lines

Holes poked for crankshaft

STEP SIX: Attach the cylinder. Make sure the connecting rod moves freely without hitting the cylinder. You may have to slide the cylinder forward to keep the connecting rod from contacting the cylinder at the back.

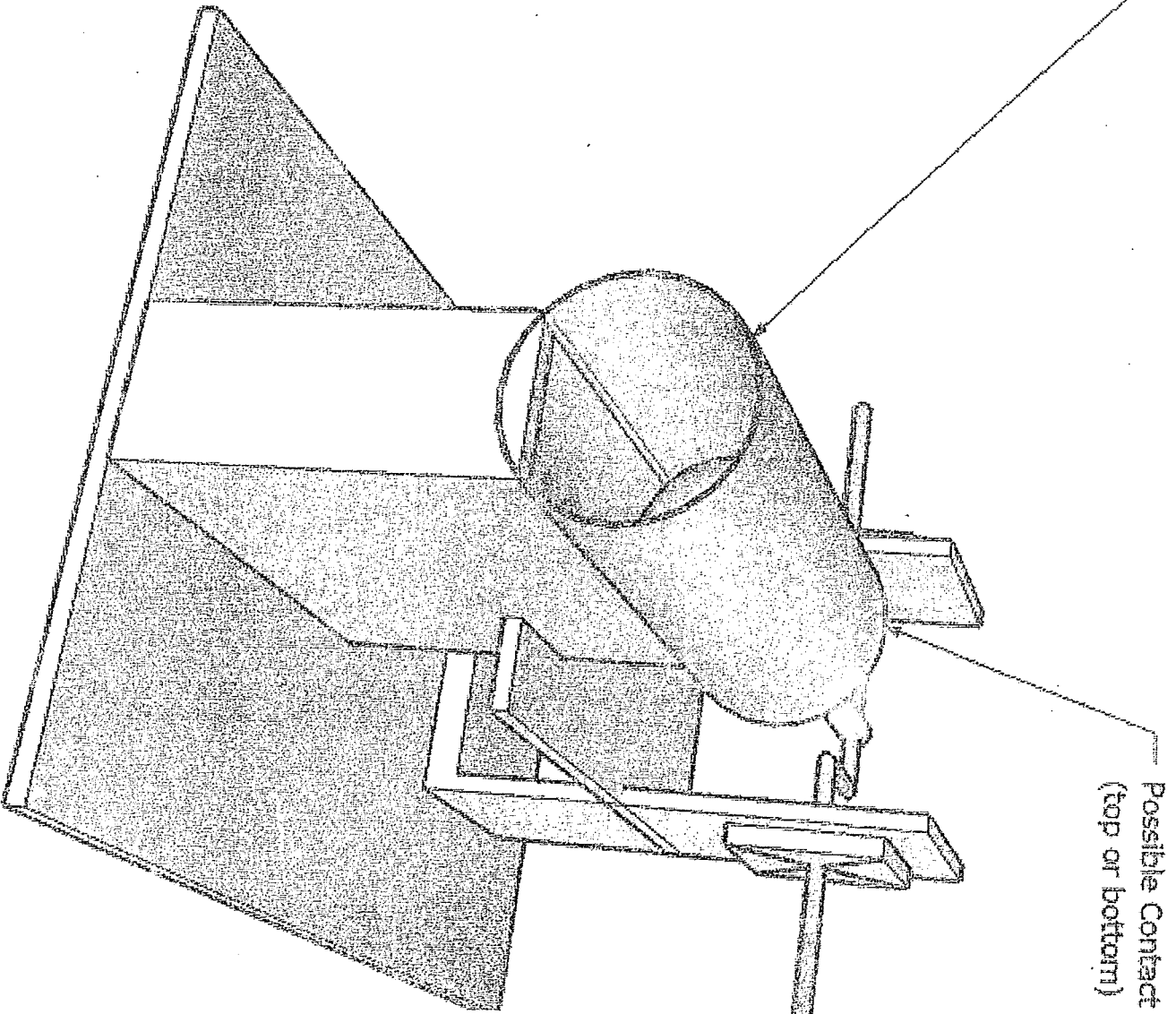

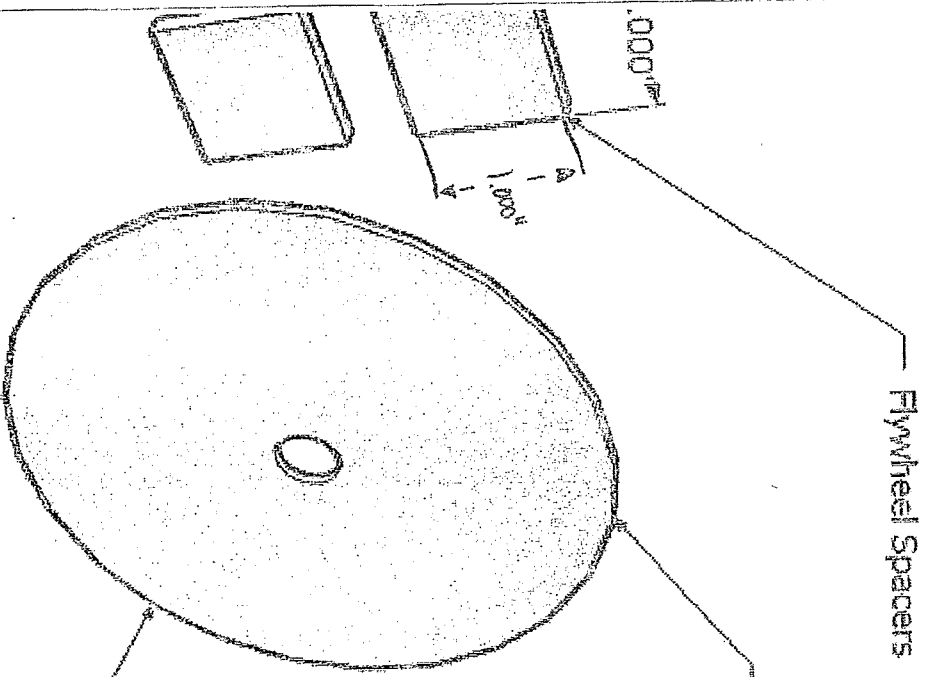

Flywheel and Spacers

STEP SEVEN: Glue the flywheel spacers to the CD (one on each side). Poke a small hole through the center of both spacers. Make TWO of these!

STEP EIGHT: Attach the two flywheels to the engine. Try it out!

